

12x40-60
12x40-75
12x40-100

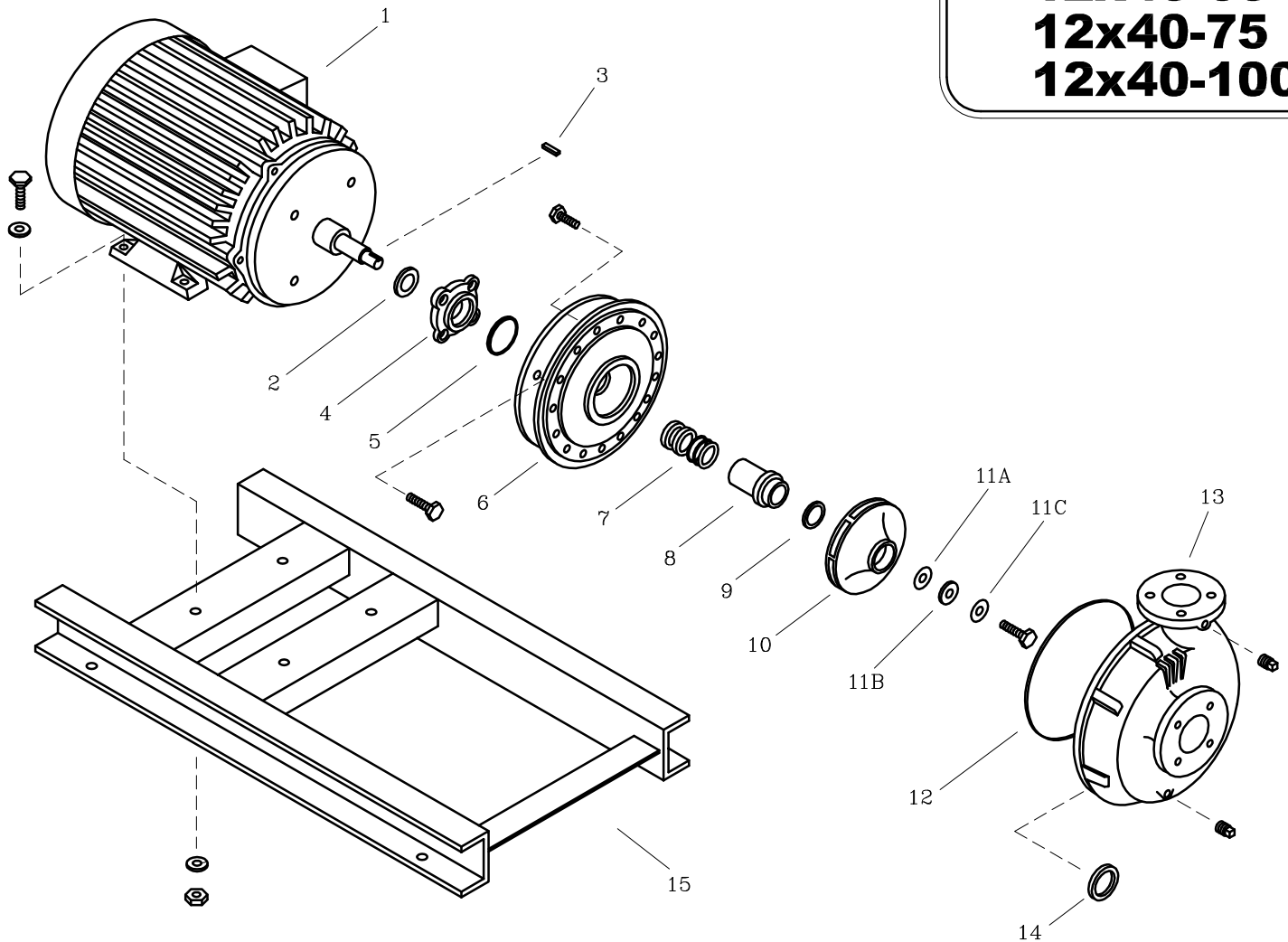

LISTA DE REPUESTOS			CANTIDAD		
ITEM No.	DESCRIPCION	CODIGO	12x40-60	12x40-75	12x40-100
* 1	MOTOR ELECTRICO 1750 RPM	SEGUN POTENCIA	1	1	1
2	DEFLECTOR 43.5 mm. DIA. INT.	7800600051	1	1	1
3	CUÑA 1/4"x45 mm.	7711500041	1	1	1
4	PRENSA SELLO EUROLINEA T3-326	03041C0041	1	1	1
5	AROSSELLO REF. 2-150	0306000051	1	1	1
6	PLATO SELLO EUROLINEA T3-326JM	0307700021	1	1	1
7	SELLO MECANICO ϕ 1.1/2" TIPO 21	7712000051	1	1	1
8	CASQUILLO S.M. 10x40-100	89174C0041	1	1	1
9	AROSSELLO ROTOR	7711300051	1	1	1
10	ROTOR 12x40-60 300 mm.	03082B0021	1	-	-
10	ROTOR 12x40-75 330 mm.	03082A0021	-	1	-
10	ROTOR 12x40-100 365 mm.	0308200021	-	-	1
11A	EMPAQUE ARANDELA ROTOR	7711600043	1	1	1
11B	ARANDELA ROTOR 17/32" DI x 48 DE	0307800041	1	1	1
11C	ARANDELA DE COBRE 17/32"	8837700056	1	1	1
12	EMPAQUE CARCASA 12x40	8839200043	1	1	1
13	CARCASA ANILLO 12x40	8838100021	1	1	1
14	ANILLO DE FRICCION 12x25	8705400022	1	1	1
15	BASE 10x40-60-75	0310800046	1	1	-
15	BASE 10x40-100	0310900046	-	-	1

* Para servicio o reparacion del motor, tenga en cuenta el modelo y características contenidas en la placa del mismo.

- Tornilleria estandar se ilustra unicamente.