

5x26-7.5
5x26-10

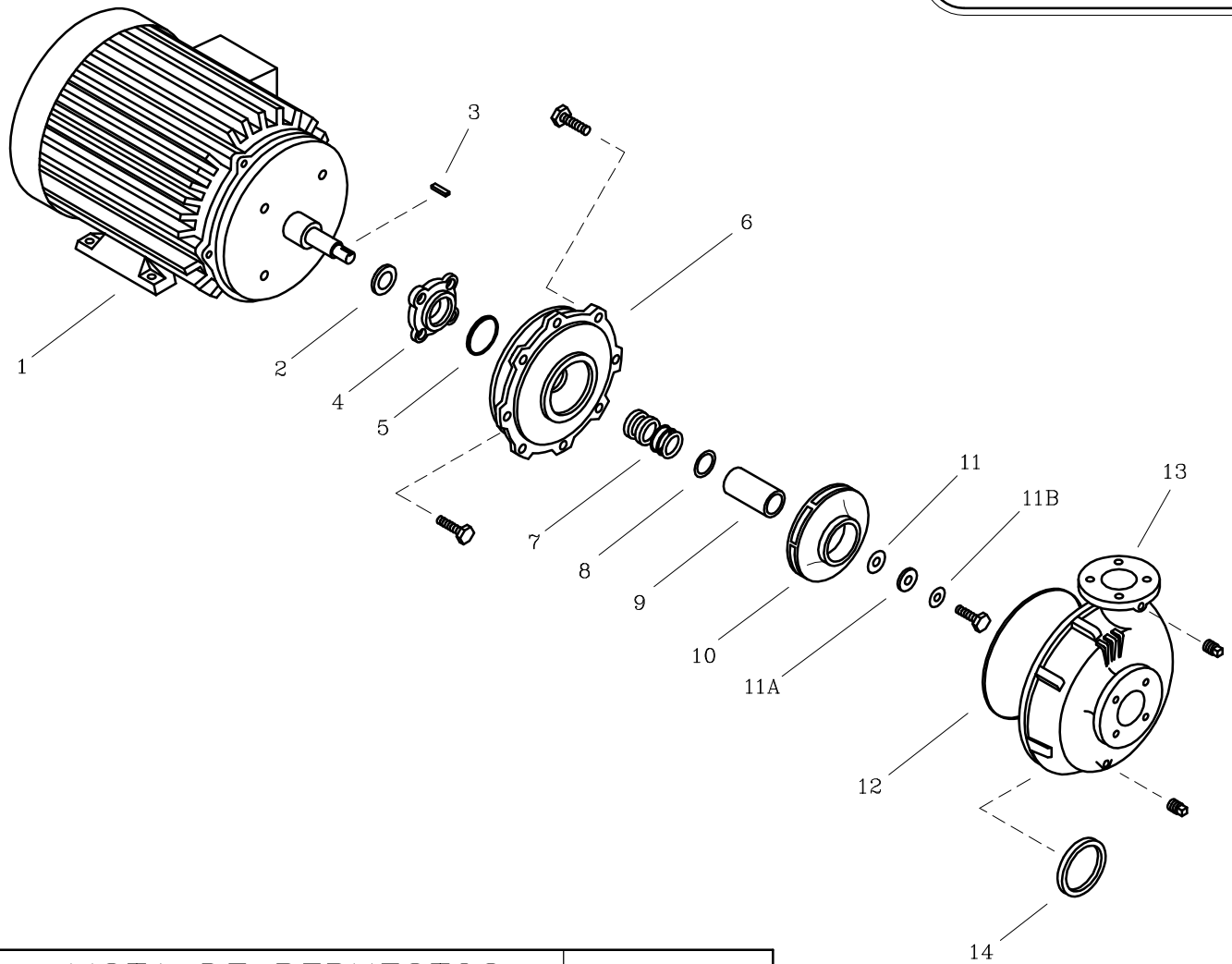

LISTA DE REPUESTOS			CANTIDAD	
ITEM No.	DESCRIPCION	CODIGO	5x26-7.5TW	5x26-10TW
* 1	MOTOR ELECTRICO 1750 RPM	SEGUN POTENCIA	1	1
2	DEFLECTOR 29.3 mm. DIA. INT.	7220000051	1	—
2	DEFLECTOR 37 mm. DIA. INT.	7110200051	—	1
3	CUÑA 3/16"x25 mm.	7707100041	1	1
4	PRENSA SELLO EUROL. T1-184-215	0304100021	1	1
5	AROSSELLO REF. 2-150	0306000051	1	1
6	PLATO SELLO EUROLINEA T1-184JM	0302900021	1	—
6	PLATO SELLO EUROLINEA T1-215JM	0306300021	—	1
7	SELLO MECANICO ϕ 1.1/4" TIPO 21	8032500051	1	1
8	AROSSELLO REF. 2-015	9308000051	1	1
9	CASQUILLO S.M. 1.1/4"x59.3 mm.	8509600041	1	1
10	ROTOR 5x26-7.5 240 mm.	03095A0021	1	—
10	ROTOR 5x26-10 264 mm.	0309500021	—	1
11	EMPAQUE ARANDELA ROTOR	7707000043	1	1
11A	ARANDELA ROTOR	7706600044	1	1
11B	ARANDELA DE COBRE 10 mm.	8012500056	1	1
12	EMPAQUE CARCASA 4x26	9301400043	1	1
13	CARCASA ANILLO 5x26	9406300021	1	1
14	ANILLO DE FRICCION II 8x40x2	8718400022	1	1

* Para servicio o reparacion del motor, tenga en cuenta el modelo y características contenidas en la placa del mismo.
— Tornilleria estandar se ilustra unicamente.