

5x25-15
5x25-20
5x25-25

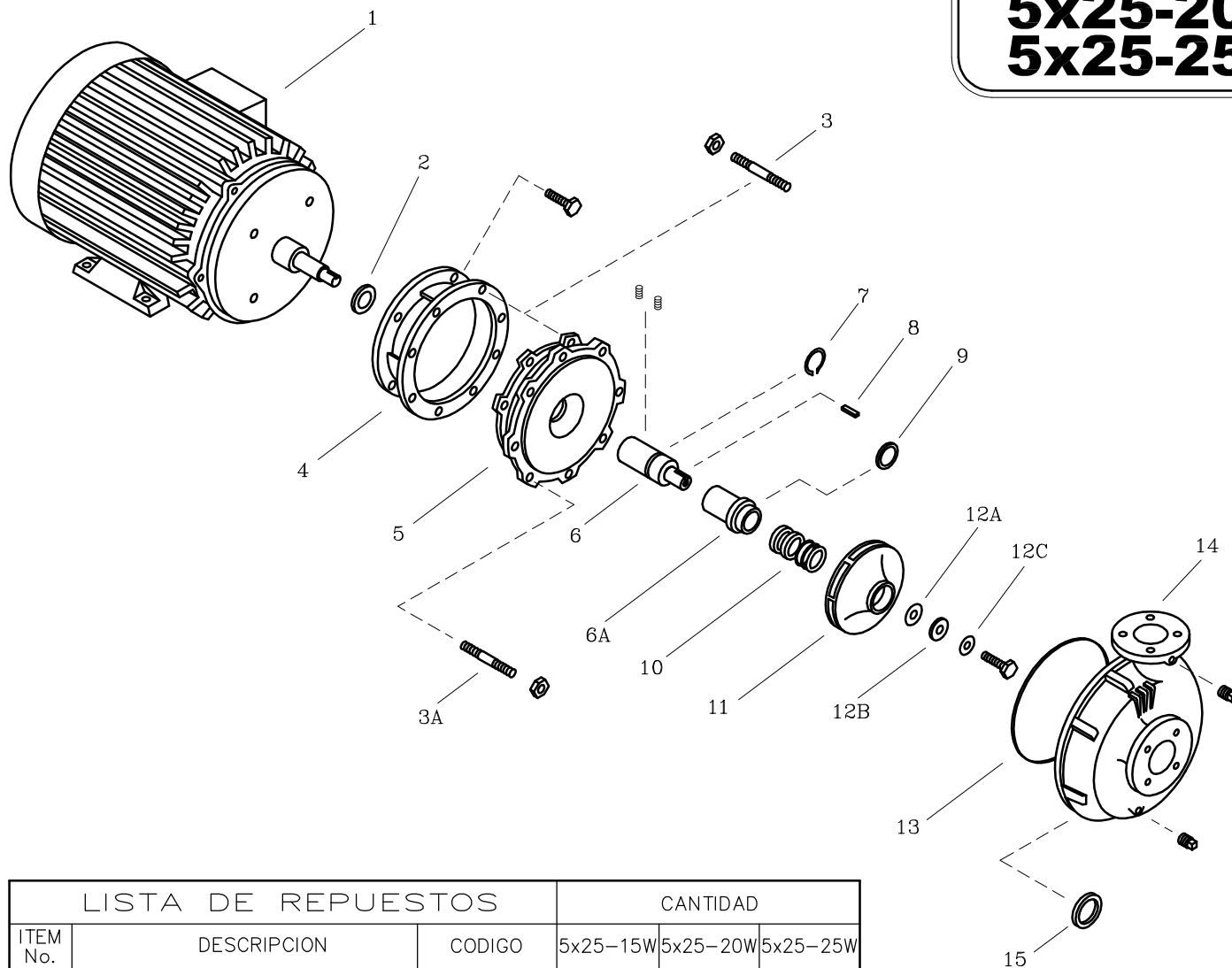

LISTA DE REPUESTOS			CANTIDAD		
ITEM No.	DESCRIPCION	CODIGO	5x25-15W	5x25-20W	5x25-25W
* 1	MOTOR ELECTRICO 3500 RPM	SEGUN POTENCIA	1	1	1
2	DEFLECTOR 29.3 mm. DIA. INT.	7220000051	1	-	-
2	DEFLECTOR 43.5 mm. DIA. INT.	7800600051	-	1	1
3	ESPARRAGO NC. 1/2"x60 mm.	8604700044	8	8	8
3A	ESPARRAGO NC. 1/2"x53 mm.	8601000044	8	8	8
4	ADAPTADOR 5x20-18.0	8917300021	1	1	1
5	PLATO SELLO 5x25-24	9300300021	1	1	1
6	EJE EXTENSION 5x20-18.0	8917600041	1	-	-
6A	CASQUILLO S.M. 5x20-28.0	8917400041	-	1	1
7	ANILLO RETEN. ROD. A-38	8703500052	1	-	-
8	CUÑA ROTOR 1/4"x1/4"x30 mm.	8836400041	1	1	1
9	AROSSELLO ROTOR	7711300051	-	1	1
10	SELLO MECANICO ϕ 1.1/2" TIPO 21	7712000051	1	1	1
11	ROTOR 5x25-18 191 mm.	93010A2021	1	-	-
11	ROTOR 5x25-24 210 mm.	93010A1021	-	1	-
11	ROTOR 5x25-28 229 mm.	93010A0021	-	-	1
12A	EMPAQUE ARANDELA ROTOR 3x20	9207300043	1	1	1
12B	ARANDELA ROTOR 13.5DI x 36DE	9203800041	1	1	1
12C	ARANDELA DE COBRE 17/32"	8837700056	1	1	1
13	EMPAQUE CARCASA 5x25	9301200043	1	1	1
14	CARCASA ANILLO 5x25	9214000021	1	1	1
15	ANILLO DE FRICCION 5x25	9301100022	1	1	1

* Para servicio o reparacion del motor, tenga en cuenta el modelo y características contenidas en la placa del mismo.

- Tornilleria estandar se ilustra unicamente.