

10x16-7.5
10x16-10
10x16-15
10x16-20

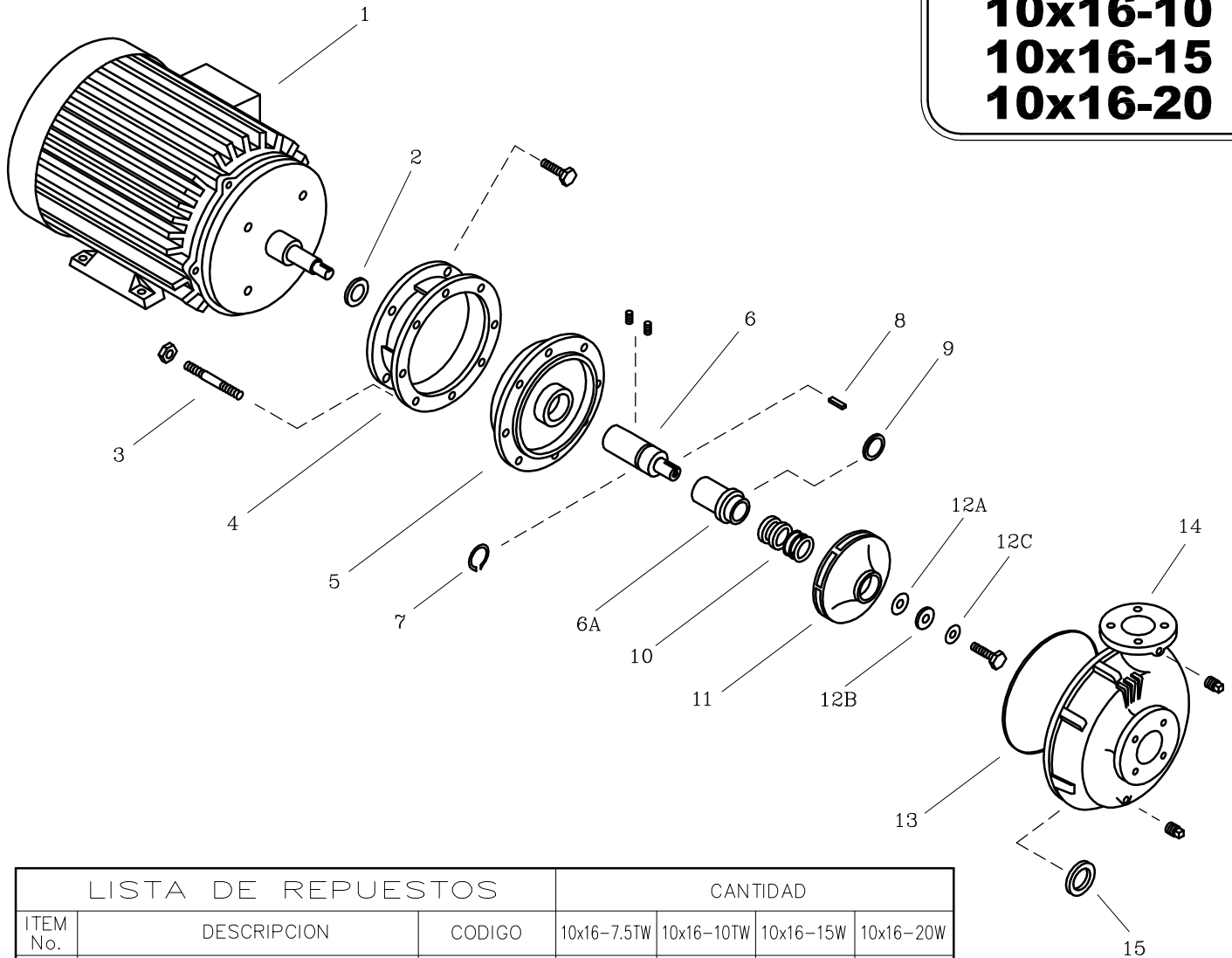

LISTA DE REPUESTOS			CANTIDAD			
ITEM No.	DESCRIPCION	CODIGO	10x16-7.5TW	10x16-10TW	10x16-15W	10x16-20W
* 1	MOTOR ELECTRICO 3500 RPM	SEGUN POTENCIA	1	1	1	1
2	DEFLECTOR 29.3 mm. DIA. INT.	7220000051	1	1	1	—
2	DEFLECTOR 43.5 mm. DIA. INT.	7800600051	—	—	—	1
3	ESPARRAGO NC. 1/2"x60 mm.	8604700044	8	8	8	8
4	ADAPTADOR 5x20-18.0	8917300021	1	1	1	1
5	PLATO SELLO 5x20-18.0	8917200021	1	1	1	1
6	EJE EXTENSION 5x20-18.0	8917600041	1	1	1	—
6A	CASQUILLO S.M. 5x20-28.0	0302800041	—	—	—	1
7	ANILLO RETEN. ROD. A-38	8703500052	1	1	1	—
8	CUÑA ROTOR 1/4"x1/4"x30 mm.	8836400041	1	1	1	1
9	AROSSELLO ROTOR	7711300051	—	—	—	1
10	SELLO MECANICO ø1.1/2" TIPO 21	7712000051	1	1	1	1
11	ROTOR 10x16-9 133 mm.	93016A3021	1	—	—	—
11	ROTOR 10x16-12 146 mm.	93016A2021	—	1	—	—
11	ROTOR 10x16-18 162 mm.	93016A1021	—	—	1	—
11	ROTOR 10x16-24 171 mm.	93016A0021	—	—	—	1
12A	EMPAQUE ARANDELA ROTOR 3x20	9207300043	1	1	1	1
12B	ARANDELA ROTOR 21/32 DIX36 DE	92038A0041	1	1	1	1
12C	ARANDELA DE COBRE 17/32"	8837700056	1	1	1	1
13	EMPAQUE CARC. P/SELLO 4x13	9208600051	1	1	1	1
14	CARCASA ANILLO 10x16	9301500021	1	1	1	1
15	ANILLO DE FRICCION 10x16	9301700022	1	1	1	1

* Para servicio o reparación del motor, tenga en cuenta el modelo y características contenidas en la placa del mismo.

— Tornillería estándar se ilustra únicamente.