

6x26 PE
6x26 SM

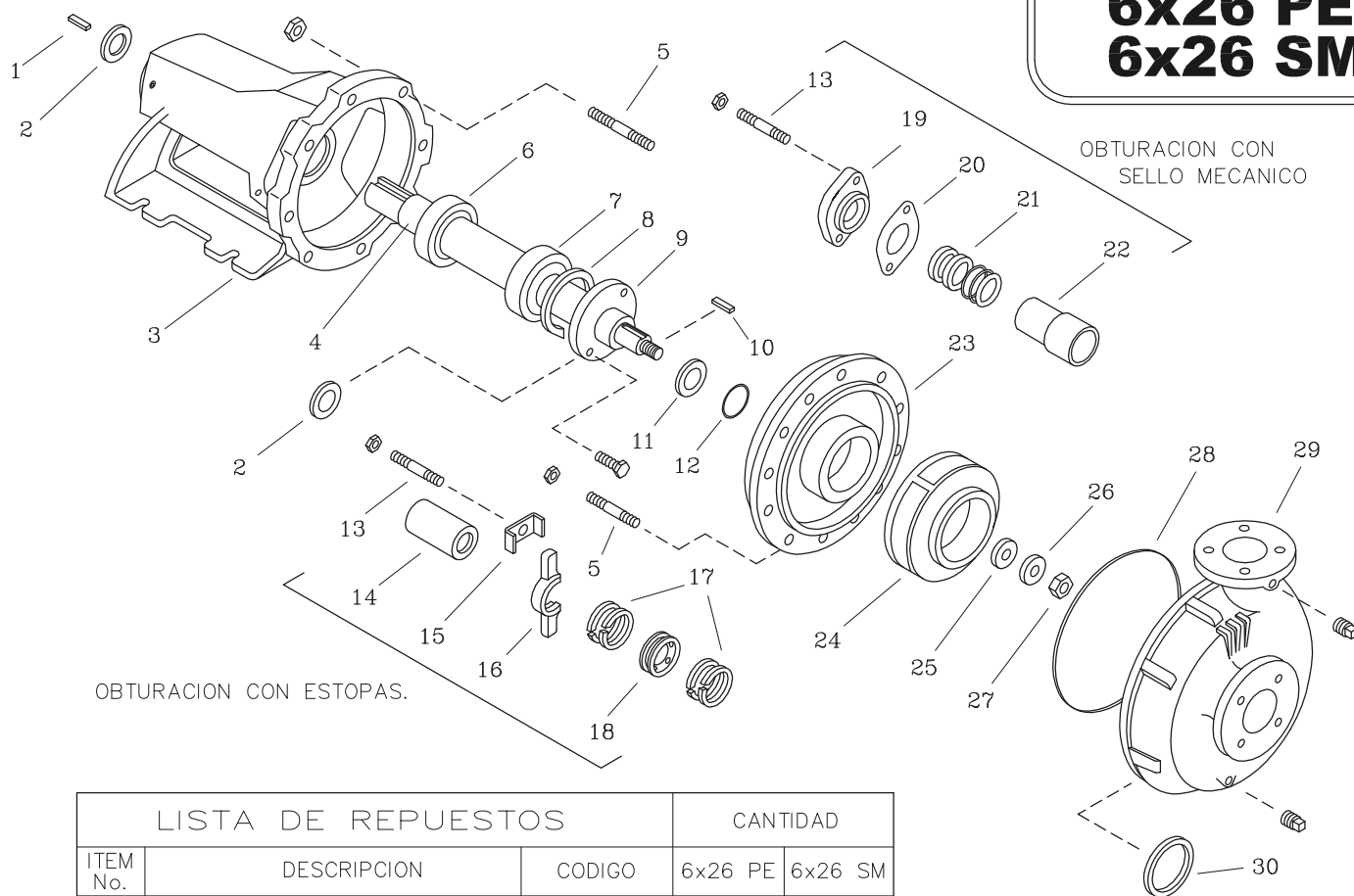

LISTA DE REPUESTOS			CANTIDAD	
ITEM No.	DESCRIPCION	CODIGO	6x26 PE	6x26 SM
1	CUÑA 1/4"x45 mm.	7711500041	1	1
2	FILTRO SOP. ROD. No.2	8836700043	2	2
3	SOPORTE ROD. No.2	8835300021	1	1
4	EJE 5x20	8836000041	1	1
5	ESPARRAGO NC. 1/2"x53 mm.	8601000044	20	20
6	RODAMIENTO 6206-2Z	8629200052	1	1
7	RODAMIENTO 7306B	8837500052	1	1
8	ANILLO RETEN. ROD. I-72	8837600052	1	1
9	TAPA ANTERIOR SOP. ROD. No.2	8835500021	1	1
10	CUÑA ROTOR 1/4"x1/4"x30 mm.	8836400041	1	1
11	DEFLECTOR 28 mm. DIA. INT.	8837400051	1	1
12	AROSSELLO REF. 2-024	1300200051	1	1
13	ESPARRAGO NC. 3/8"x48 mm.	7110300044	2	2
14	CASQUILLO P.E. No.2	8836100041	1	-
15	GRAPA PRENSA ESTOPA No.2	8837300044	2	-
16	PRENSA ESTOPA No.2	8835600021	2	-
17	CORDON PLOMBAGINADO 5/16"x5/16"	7582500033	0.6 Kg.	-
18	ANILLO LINTERNA No.2	8835900022	1	-
19	PRENSA SELLO No.2	8835700021	-	1
20	EMPAQUE PRENSA SELLO No.2	8837000043	-	1
21	SELLO MECANICO 1.1/4" TIPO 21	8032500051	-	1
22	CASQUILLO S.M. No.2 INOX	8836200041	-	1
23	PLATO ESTOPA 3x26	9407300021	1	1
24	ROTOR 6x26 264 mm. CUN 1/4"	9406600021	1	1
25	EMPAQUE ARAND.ROTOR 21/32 DI	88368A0043	1	1
26	ARANDELA ROTOR 21/32 DIx42 DE	86028A0041	1	1
27	TUERCA DE SEGURIDAD NF 5/8"	9705700056	1	1
28	EMPAQUE CARC. P/SELLO 4x26	9301400043	1	1
29	CARCASA ANILLO 6x26	9406500021	1	1
30	ANILLO DE FRICCION II 8x40x2 PE	8718400022	1	1

- Tornilleria estandar se ilustra unicamente.